

Cervoz Industrial Memory Card

CFast

Reliance Series (RO-MLC)

R350 Family

Product Datasheet



Date: 2022.02.11

Revision: 1.3

File: Cervoz_Industrial_Memory_Card_CFast_R350_Datasheet_Rev1.3



Revision History

Date	Revision	Description
2017.12.14	1.0	First Released
2019.10.01	1.1	1.3 Wide Temperature Solution Added
2020.10.29	1.2	16GB Added
2022.02.11	1.3	Modify the 2.1 MTBF / TBW data



Table of Contents

1. Product Overview.....	4
1.1 Introduction.....	4
1.2 Feature.....	4
1.3 Product Appearance & Models.....	5
2. Product Specifications.....	6
2.1 General Specifications.....	6
2.2 Performance.....	6
2.3 Electronic Specifications.....	7
2.3.1 Block Diagram.....	7
2.3.2 Pin Assignment.....	8
2.4 Environmental Specifications.....	9
2.5 Mechanical Specifications.....	9
3. Supported Command.....	10
3.1 List of Command Sets.....	10~11
4. Part No. Decoder.....	12
4.1 Part No. Decoder.....	12~13

1. Product Overview

1.1 Introduction

Cervoz Industrial CFast Card R350 is a high capacity Solid State Flash Disk product that is in compliance with the CFast and SATA III standards. The device design is based on the 7pin for data segment and 17pin for power and controller segment. The R350 CFast card is in low profile form factor and fits in any systems with CFast slots.

R350 uses preselected multi-level cell (MLC) NAND flash memory from the industry leading manufacturer Toshiba and utilizes our “Reliability Optimized-MLC (RO-MLC) Technology”. We adopt specialized firmware to control MLC NAND flash which only uses the strong pages of MLC NAND as storage; the technology is manipulated at the block level, and with each block's capacity halved by treating it as SLC. This product includes various capacities to choose from.

R350 offers high performance with reliability and endurance, as well as a remarkable price-performance ratio, ideal for applications in harsh environments. Industrial PC/Embedded PC, Factory Automation, Transportation, Information & Entertainment and Server & Cloud Computing all benefit from this superior reliability and cost-effectiveness.

1.2 Feature

- Compliant with SATA III 6.0Gb/s
- MLC NAND flash memory with RO-MLC technology
- Capacity: 16GB ~ 64GB
- Operating as boot disk
- Static and dynamic wear leveling
- Bad block management
- S.M.A.R.T. & TRIM command

1.3 Product Appearance & Models

Cervoz Industrial CFast Card R350



R350 Family Standard Temp. (0°C ~ 70°C) Model No.	R350 Family Wide Temp. (-40°C ~ 85°C) Model No.	Capacity
CIM-CAR350TKD016GS	CIM-CAR350TKD016GW	16GB
CIM-CAR350TKD032GS	CIM-CAR350TKD032GW	32GB
CIM-CAR350TLD064GS	CIM-CAR350TLD064GW	64GB

Please Note:

Since certain storage capacity has to be reserved for firmware and controller management purposes; the physical capacity of the SATA flash module will be approximately 92.5% of the indicated capacity. If you need to install an image that has the exact (or close to) the indicated size of the flash module, please choose your flash module with a greater capacity.

2. Product Specifications

2.1 General Specifications

Form Factor	CFast
Interface	SATA III 6.0Gb/s (backward compatible to 3.0Gb/s, 1.5Gb/s)
Connector	SATA (7+17 pin)
NAND Flash Type	MLC (Controlled by Reliability Optimized-MLC Technology)
Capacity	16GB/32GB/64GB
Sequential Read	up to 510MB/s
Sequential Write	up to 450MB/s
ECC Scheme	Applies the LDPC (Low Density Parity Check) of ECC algorithm
MTBF	>3,000,000 hours
TeraByte Written (TBW)	16GB : 130.2 32GB : 260.4 64GB : 520.8
Low Power Management	DIPM/HIPM mode
Supply Voltage	3.3V DC +/-5%
Power Consumption	Active mode: < 1475mW Idle mode: < 260mW
Dimension (LxWxH)	42.8*36.4*3.3mm

2.2 Performance

The performance was measured with below PC configuration:

- Platform: GIGABYTE GA-Z97MX-Gaming5 (Intel Z97)
- RAM: Cervoz CIR-S3DUSI1302G(DDR3 2G 1333MHz)
- Operation Systems: Win10 64bit
- Testing Utility: Crystal Disk Mark v5.1.0
- SATAIII port (6.0 Gb/s) performance

Capacity	16GB	32GB	64GB
Sequential Read (max.)	355MB/s	490MB/s	510MB/s
Sequential Write (max.)	165MB/s	330MB/s	450MB/s
4KB Random Read (QD32)	160MB/s	280MB/s	375MB/s
4KB Random Write (QD32)	160MB/s	305MB/s	340MB/s

Actual performance may vary depending on use conditions and environment

2.3 Electronic Specifications

2.3.1 Block Diagram

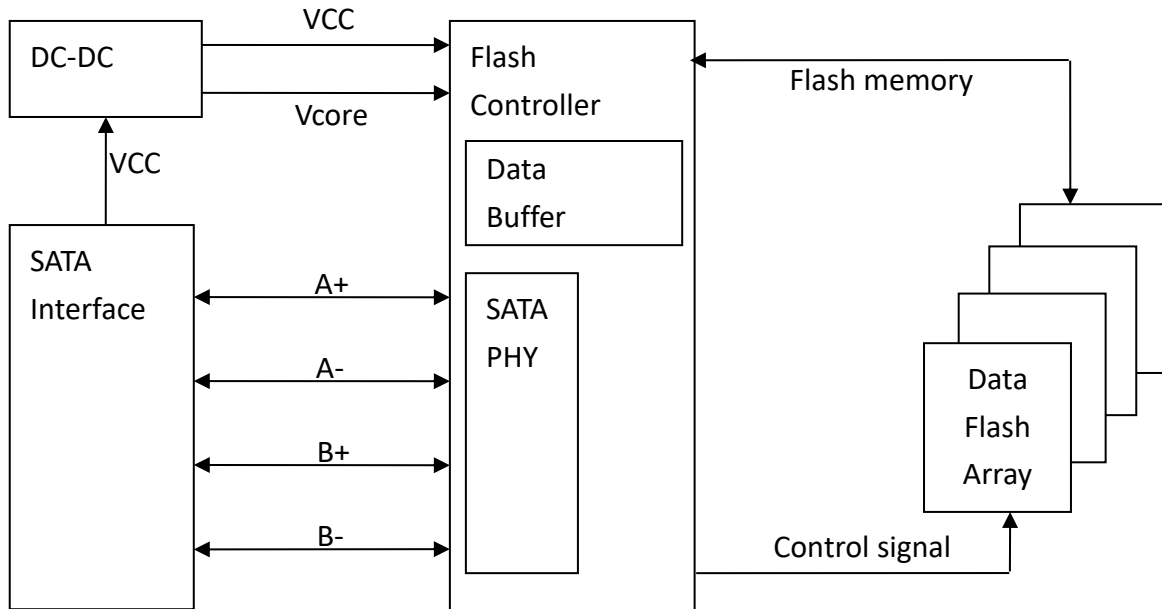

2.3.2 Pin Assignment

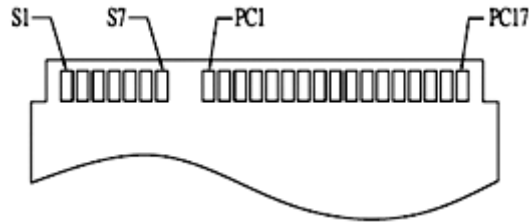

Pin #	Segment	Pin Definition	Type	Description	Meting Sequence
S1	SATA	SGND	Signal GND	Ground for signal integrity	1 st
S2	SATA	A+	SATA Differential	Signal Pair A	2 nd
S3	SATA	A-	SATA Differential	Signal Pair A	2 nd
S4	SATA	SGND	Signal GND	Ground for signal integrity	1 st
S5	SATA	B-	SATA Differential	Signal Pair B	2 nd
S6	SATA	B+	SATA Differential	Signal Pair B	2 nd
S7	SATA	SGND	Signal GND	Ground for signal integrity	1 st
	Key				
	Key				
PC1	PWR/CTL	CDI	Input	Card Detect In	3 rd
PC2	PWR/CTL	PGND	Device GND		1 st
PC3	PWR/CTL	DEVSLP	DEVSLP Card Input	DevSleep Power State Enable	2 nd
PC4	PWR/CTL			Reserved	2 nd
PC5	PWR/CTL			Reserved	2 nd
PC6	PWR/CTL			Reserved	2 nd
PC7	PWR/CTL	PGND	Device GND		1 st
PC8	PWR/CTL	LED1	LED Output	LED Output	2 nd
PC9	PWR/CTL	LED2	LED Output	LED Output	2 nd
PC10	PWR/CTL			Reserved	2 nd
PC11	PWR/CTL			Reserved	2 nd
PC12	PWR/CTL	IFDet	GND	Card output, connect to PGND on card	2 nd
PC13	PWR/CTL	PWR	3.3V	Device Power (3.3V)	2 nd
PC14	PWR/CTL	PWR	3.3V	Device Power (3.3V)	2 nd
PC15	PWR/CTL	PGND	Device GND	Device Ground	1 st
PC16	PWR/CTL	PGND	Device GND	Device Ground	1 st
PC17	PWR/CTL	CDO	Output	Card Detect Out	3 rd

2.4 Environmental Specifications

Type		Value
Temperature	Standard Temperature Operating:	0°C~70°C
	Standard Temperature Storage:	-40°C~85°C
	Wide Temperature Operating:	-40°C~85°C
	Wide Temperature Storage:	-50°C~95°C
Humidity	Operating & Storage	10~95%, Non-Condensing
Vibration	Non-Operating	20G, 10Hz~2000Hz
Shock	Non-Operating	1500G, 0.5ms

2.5 Mechanical Specifications

Type	Value
Form Factor	CFast
Length	42.80mm +/-0.10mm
Width	36.40mm +/-0.15mm
Thickness	3.30mm +/-0.10mm

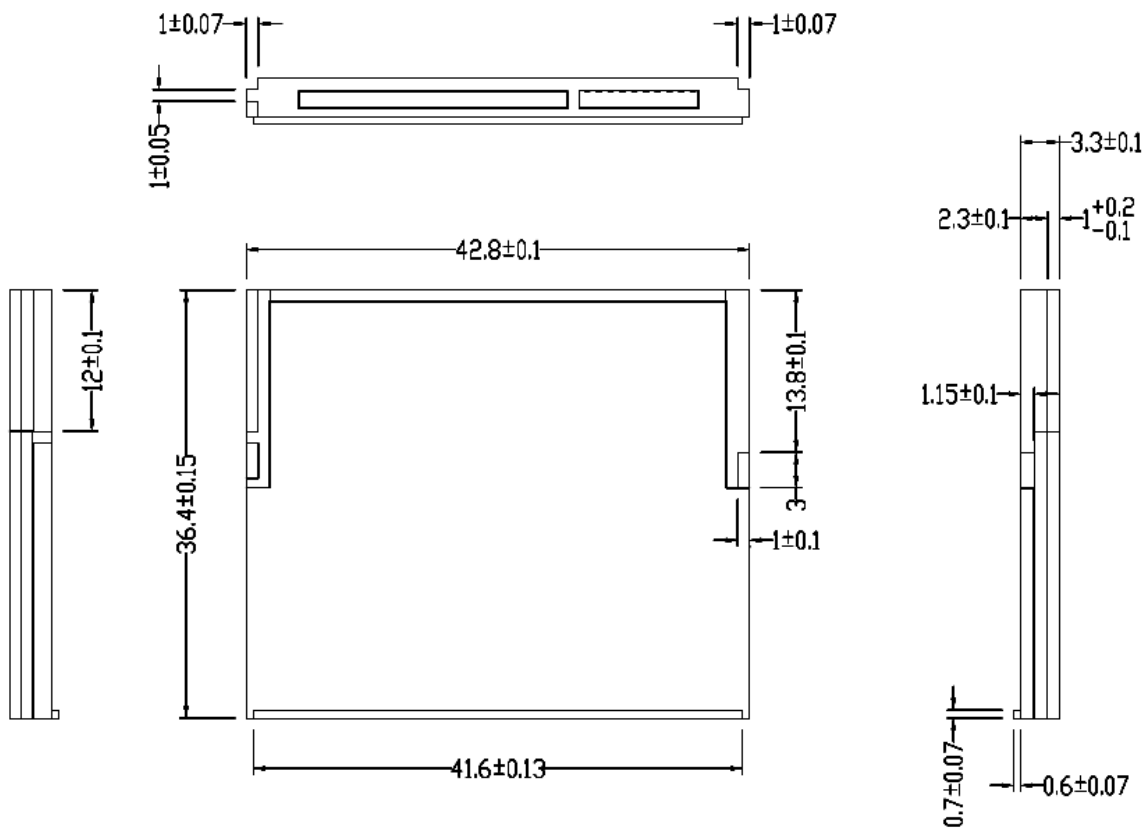

3. Supported Command

3.1 List of Command Sets

Code	Description	Code	Description
00h	NOP	B0h, D1h	SMART READ DATA ATTRIBUTE THRESHOLD
06h	Data Set Management	B0h, D2h	SMART ENABLE/DISABLE ATTRIBUTE AUTOSAVE
10h	Recalibrate	B0h, D3h	SMART SAVE ATTRIBUTE VALUES
20h	Read Sectors	B0h, D4h	SMART EXECUTE OFF-LINE IMMEDIATE
21h	Read Sectors without Retry	B0h, D5h	SMART READ LOG
24h	Read Sectors EXT	B0h, D6h	SMART WRITE LOG
25h	Read DMA EXT	B0h, D8h	SMART ENABLE OPERATIONS
27h	Read Native Max Address EXT	B0h, D9h	SMART DISABLE OPERATIONS
29h	Read Multiple EXT	B0h, DAh	SMART RETURN STATUS
2Fh	Read Log EXT	B0h, DBh	SMART ENABLE/DISABLE AUTOMATIC OFF-LINE
30h	Write Sectors	B1h	DEVICE CONFIGURATION OVERLAY
31h	Write Sectors without Retry	B1h, C0h	DEVICE CONFIGURATION RESTORE
34h	Write Sectors EXT	B1h, C1h	DEVICE CONFIGURATION FREEZE LOCK
35h	Write DMA EXT	B1h, C2h	DEVICE CONFIGURATION IDENTIFY
37h	Set Native Max Address EXT	B1h, C3h	DEVICE CONFIGURATION SET
39h	Write Multiple EXT	B1h, C4h	DEVICE CONFIGURATION IDENTIFY DMA
3Dh	Write DMA FUA EXT	B1h, C5h	DEVICE CONFIGURATION SET DMA
3Fh	Write Long EXT	C4h	Read Multiple
40h	Read Verify Sectors	C5h	Write Multiple
41h	Read Verify Sectors without Retry	C6h	Set Multiple Mode
42h	Read Verify Sectors EXT	C8h	Read DMA
45h	Write Uncorrectable EXT	C9h	Read DMA without Retry
47h	Read Log DMA EXT	CAh	Write DMA
57h	Write Log DMA EXT	CBh	Write DMA without Retry
60h	Read FPDMA Queued	CEh	Write Multiple FUA EXT
61h	Write FPDMA Queued	E0h	Standby Immediate
70h	Seek	E1h	Idle Immediate
90h	Execute Device Diagnostic	E2h	Standby
91h	Initialize Device Parameters	E3h	Idle
92h	Download Microcode	E4h	Read Buffer
93h	Download Microcode DMA	E5h	Check Power Mode
B0h	SMART	E6h	Sleep
B0h, D0h	SMART READ DATA	E7h	Flush Cache

Code	Description	Code	Description
E8h	Write Buffer	Efh, 82h	Disable write cache
E9h	Read Buffer DMA	Efh, 85h	Disable advanced power management
EAh	Flush Cache EXT	Efh, 90h	Disable use of Serial ATA feature set
EBh	Write Buffer DMA	Efh, 90h, 02h	Disable DMA Setup FIS Auto-Activate optimization
ECh	Identify Device	Efh, 90h, 03h	Disable Device-initiated interface power state (DIPM) transitions
EFh	Set Features	Efh, 90h, 06h	Disable Software Settings Preservation (SSP)
Efh, 02h	Enable 8-bit PIO transfer mode	Efh, 90h, 07h	Disable Device Automatic Partial to Slumber transitions
Efh, 03h	Set transfer mode based on value in Count field	Efh, 90h, 09h	Disable Device Sleep
Efh, 05h	Enable advanced power management	Efh, AAh	Enable read look-ahead feature
Efh, 10h	Enable use of Serial ATA feature	Efh, CCh	Enable reverting to power-on defaults
Efh, 10h, 02h	Enable DMA Setup FIS Auto-Activate optimization	F1h	Security Set Password
Efh, 10h, 03h	Enable Device-initiated interface power state (DIPM) transitions	F2h	Security Unlock
Efh, 10h, 06h	Enable Software Settings Preservation (SSP)	F3h	Security Erase Prepare
Efh, 10h, 07h	Enable Device Automatic Partial to Slumber transitions	F4h	Security Erase Unit
Efh, 10h, 09h	Enable Device Sleep	F5h	Security Freeze Lock
Efh, 55h	Disable read look-ahead feature	F6h	Security Disable Password
Efh, 66h	Disable reverting to power-on defaults	F8h	Read Native Max Address

4. Part No. Decoder

4.1 Part No. Decoder

1	-	2	3	4	5	6	7	8	9
Product Line	-	Form Factor	Product Series	Cervoz Family Code (Bus / Internal Control)	Flash Brand	Flash Capacity	Flash Mode	Module Capacity	Operating Temp.
XXX	-	XX	X	XXX	X	X	X	XXXX	X

1. Product Line

CIS	Cervoz Industrial SSD
CIM	Cervoz Industrial Memory Card
CIE	Cervoz Industrial Embedded Module

2. Form Factor

2S	2.5" SATA
2P	2.5" PATA
CF	CompactFlash
CA	CFast
MS	mSATA
HM	Half Size mSATA
HS	Half Slim
M4	M.2 2242
M6	M.2 2260
M8	M.2 2280
0V	PATA Disk 40pin Vertical
4V	PATA Disk 44pin Vertical
4L	PATA Disk 44pin Horizontal Left
7T	SATA Disk 7pin Vertical Tall
7L	SATA Disk 7pin Horizontal Left
7R	SATA Disk 7pin Horizontal Right

3. Product Series

S	Supreme Series (SLC)
R	Reliance Series (RO-MLC)
M	Momentum Series (MLC)

4. Cervoz Family Code

Bus and Internal Control for Cervoz Product Families

5. Flash Brand

M	Micron
T	Toshiba

6. Flash Capacity

A	256Mb
B	512Mb

C	1Gb
D	2Gb
E	4Gb
F	8Gb
G	16Gb
H	32Gb
I	64Gb
J	128Gb
K	256Gb
L	512Gb
M	1Tb

7. Flash Mode

Internal Control for Flash Mode

8. Module Capacity

128M	128MB
256M	256MB
512M	512MB
001G	1GB
002G	2GB
004G	4GB
008G	8GB
016G	16GB
032G	32GB
064G	64GB
128G	128GB
256G	256GB
512G	512GB

9. Operating Temperature

S	Standard Grade (0~ +70°C)
W	Wide Temperature Grade (-40 ~ +85°C)